



Planning documents

BASWA Cool

Classic Base

Classic Fine

Classic Top

Content

System description	3
The BASWA Cool Systems	8
<hr/>	
BASWA Cool Classic Base	9
BASWA Cool Classic Fine	11
BASWA Cool Classic Top	13
System structure	15
Heating and cooling performance	19
Planning and configuration bases	22
Installation time	27
Preparation and planning	28
<hr/>	
Requirements and prerequisites	29
Substrate for BASWA Cool Acoustic Systems	35
BASWA Colors	41
Light reflection of BASWA coatings	42
Surface structures and effects	43
Protection, cleaning, maintenance and refurbishment	44
Common construction details	48
<hr/>	
Common construction details	49
Surface connections to vertical components	50
Edge finishes	52
Spotlights, luminaires, tracks, pendants, etc.	53
Legal notice	57

System description

General information

Comfort in workspaces and various other rooms is a central requirement in modern buildings. It contributes significantly to increasing productivity and to the health of people. The seamless thermal-acoustic BASWA Cool system serves on the one hand to reduce the reverberation time in buildings, and on the other hand to adjust the room temperature by active cooling and heating without draughts. The capillary tube system integrated close to the surface and the thermally outstandingly conductive BASWA acoustic plaster redefine efficient and healthy cooling and heating, as well as a healthy indoor climate of buildings.

The BASWA Cool technology provides architects and acousticians with unique design options.

System properties and advantages:

- Sound absorption up to α_w 0.65/class C
- Flame-retardant, B-s1, d0 according to DIN EN 13501-1 (Only achieved with Base Cool as a filling layer and base layer!)
- Outstanding heating and cooling performance
Cooling capacity at $\Delta 8K$; 79.1 W/m²
Heating capacity at $\Delta 15K$; 117.7 W/m²
- Minimum system thickness of only 30mm
- Very smooth, seamless surface
- Unlimited choice of colours (RAL, NCS, etc.)
- Silent and draught-free heating/cooling
- Can be used in Minergie Eco projects
- Indoor climate: French VOC Regulation A+
- Suitable for allergy sufferers
- Sustainable and ecological through combination and use regenerative energies
- Significantly lower energy consumption = lower operating costs
- Cooling without colds: promotes health through improved indoor climate
Increases the performance and concentration ability

Suitable for processing of:

- Horizontal, inclined or vertical surfaces
- Seamless surfaces (up to the maximum size of the respective substructure)
- Convex and concave shapes (smallest possible radius 5 m)



Application areas:

- Workplaces
- Healthcare
- Entertainment
- Commerce
- Office building
- Residential construction
(free cooling/heating also in combination with heat pump)
- Humid rooms/swimming pools
- Commercial space
- Educational institutions
- Restaurants
- Hotels
- Embassy
- Administration/Justice/Government
- Theatre
- Religious

Our homepage www.baswa.com contains a list of references

Overview of the system types

BASWA Cool is available in the following system thicknesses: 30 mm/40 mm/50 mm/70 mm.

All systems can be installed directly on concrete or suspended ceilings/walls (mineral substrates).

BASWA Cool systems are seamlessly coated with two layers of the microporous BASWA acoustic plaster. The following types of the final layer are available:

- **BASWA Base** Roughest surface structure (Grain 0.7 mm)
- **BASWA Fine** Average surface structure (Grain 0.5 mm)
- **BASWA Top** Finest surface structure (Grain 0.3 mm)

BASWA Cool Classic Systems

The basis for the base and final layers are in each case glued and grouted BASWA Phon and BASWA Phon Cool acoustic panels. These are topped with capillary tube systems and filled with the thermally conductive, micro-porous filling layer BASWA Base Cool.

Base coat BASWA Base/BASWA Base Cool
Finish coat BASWA Base, Fine or Top

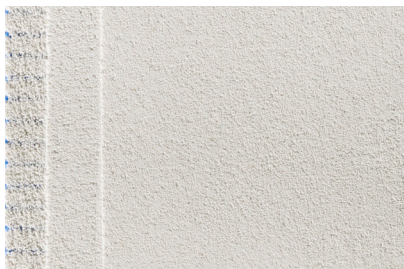

BASWA Cool Classic Base
Base coat Base/Base Cool 0.7 mm
Finish coat Base 0.7 mm

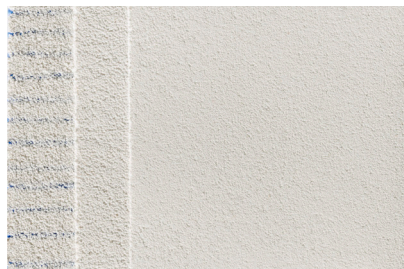

BASWA Cool Classic Fine
Base coat Base/Base Cool 0.7 mm
Finish coat Fine 0.5 mm

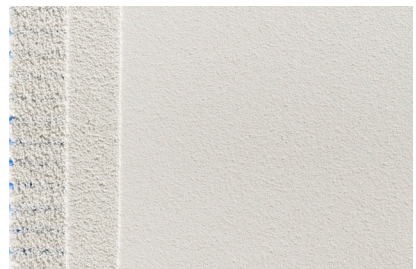

BASWA Cool Classic Top
Base coat Base/Base Cool 0.7 mm
Finish coat Top 0.3 mm

Acoustic and thermal measures

Room acoustic and thermal requirements are often ignored or downgraded for cost reasons when planning construction projects. In many cases, this makes subsequent corrections necessary. Thermal-acoustic measures are also necessary in the context of renovation or restoration of historical buildings.

BASWA Cool systems are the ideal solution for these requirements. On the one hand, because of their outstanding thermal performance, on the other hand, because of their acoustic performance, but also because of their adaptability in terms of shape, color, texture and the possibility of the smallest system thickness of 30 mm.

If BASWA Cool systems are installed on existing subfloors, the same conditions apply in terms of quality and strength as for newly created subfloors. The existing substrate must be checked by the installer for its suitability.

BASWA Cool can thus be optimally integrated into the historical building fabric of listed buildings in order to meet their acoustic and thermal requirements.

The BASWA Cool Systems

BASWA Cool Classic Base

System profile

- Two-coat system
- Seamless surface
- Grain size of the final layer 0.7 mm
- Standard color ~ NCS S 0500-N
- Surface quality Standard <Q2> Maximum <Q3>
- Resistant surface



System thickness:	System weights BASWA Cool Classic Base
-------------------	--

30 mm	~ 240 N/m ² (ca. 24 kg/m ²)
-------	--

40 mm	~ 250 N/m ² (ca. 25 kg/m ²)
-------	--

50 mm	~ 260 N/m ² (ca. 26 kg/m ²)
-------	--

70 mm	~ 280 N/m ² (ca. 28 kg/m ²)
-------	--

Sound absorption coefficients α_p (practical) according to ISO standard DIN EN ISO 11654

Solid ceilings (on concrete)

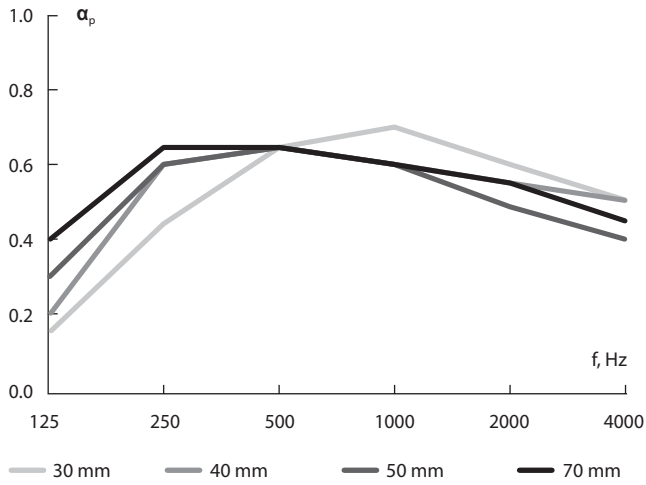

Suspension 200 mm

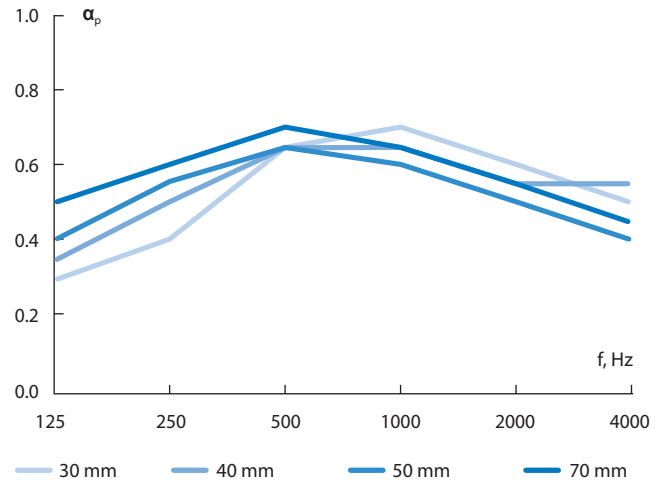

EN ISO 11654		ASTM E 1264	
Thickness	α_w	Class	NRC
30 mm	0.65	C	0.60
40 mm	0.60	C	0.60
50 mm	0.55 (L)	D	0.60
70 mm	0.60 (L)	C	0.65

EN ISO 11654		ASTM E 1264	
Thickness	α_w	Class	NRC
30 mm	0.60	C	0.60
40 mm	0.65	C	0.60
50 mm	0.55	D	0.55
70 mm	0.60	C	0.65

The complete acoustic measurement data can be found in the current test reports.

Attention! When using coloured BASWA acoustic coatings and decorative designs (e.g BASWA Textures), the specified sound absorption values may change slightly in individual cases

BASWA Cool Classic Fine

System profile

- Two-coat system
- Seamless surface
- Grain size of the final layer 0.5 mm
- Standard color ~ NCS S 0500-N
- Surface quality Standard <Q2> Maximum <Q3>
- Average surface structure



System thickness:	System weights BASWA Cool Classic Fine
-------------------	--

30 mm	~ 240 N/m ² (ca. 24 kg/m ²)
-------	--

40 mm	~ 250 N/m ² (ca. 25 kg/m ²)
-------	--

50 mm	~ 260 N/m ² (ca. 26 kg/m ²)
-------	--

70 mm	~ 280 N/m ² (ca. 28 kg/m ²)
-------	--

Sound absorption coefficients α_p (practical) according to ISO standard DIN EN ISO 11654

Solid ceilings (on concrete)

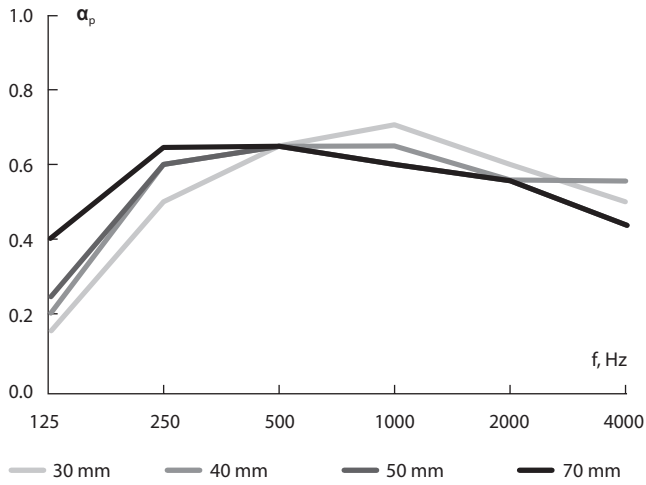

Suspension 200 mm

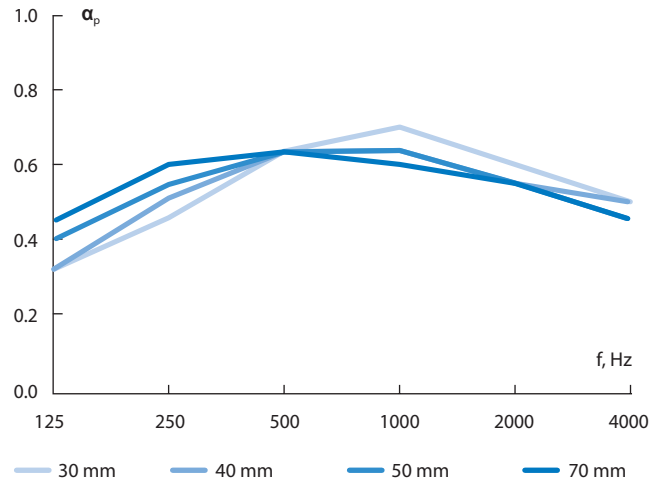

EN ISO 11654		ASTM E 1264	
Thickness	α_w	Class	NRC
30 mm	0.65	C	0.60
40 mm	0.65	C	0.60
50 mm	0.60 (L)	C	0.60
70 mm	0.60 (L)	C	0.60

EN ISO 11654		ASTM E 1264	
Thickness	α_w	Class	NRC
30 mm	0.65	C	0.60
40 mm	0.60	C	0.60
50 mm	0.60	C	0.55
70 mm	0.60	C	0.60

The complete acoustic measurement data can be found in the current test reports.

Attention! When using coloured BASWA acoustic coatings and decorative designs (e.g BASWA Textures), the specified sound absorption values may change slightly in individual cases

BASWA Cool Classic Top

System profile

- Two-coat system
- Seamless surface
- Grain size of the final layer 0.3 mm
- Standard color ~ NCS S 0500-N
- Surface quality Standard <Q2> Maximum <Q3>
- Finest, very smooth surface



System thickness:	System weights BASWA Cool Classic Top
-------------------	---------------------------------------

30 mm	~ 240 N/m ² (ca. 24 kg/m ²)
-------	--

40 mm	~ 250 N/m ² (ca. 25 kg/m ²)
-------	--

50 mm	~ 260 N/m ² (ca. 26 kg/m ²)
-------	--

70 mm	~ 280 N/m ² (ca. 28 kg/m ²)
-------	--

Sound absorption coefficients α_p (practical) according to ISO standard DIN EN ISO 11654

Solid ceilings (on concrete)

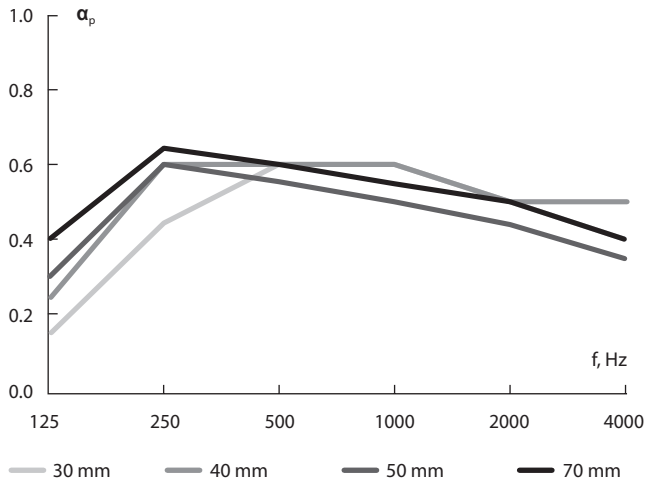

Suspension 200 mm

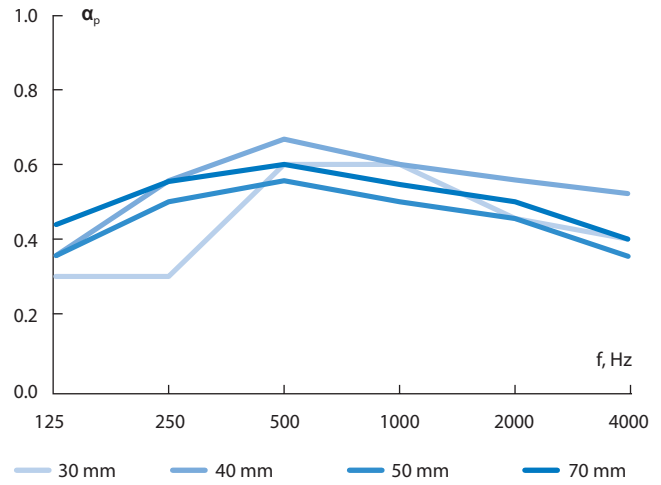

EN ISO 11654		ASTM E 1264	
Thickness	α_w	Class	NRC
30 mm	0.55	D	0.55
40 mm	0.60	C	0.60
50 mm	0.50 (L)	D	0.50
70 mm	0.55 (L)	D	0.55

EN ISO 11654		ASTM E 1264	
Thickness	α_w	Class	NRC
30 mm	0.50	D	0.50
40 mm	0.60	C	0.55
50 mm	0.50	D	0.50
70 mm	0.55	D	0.55

The complete acoustic measurement data can be found in the current test reports.

Attention! When using coloured BASWA acoustic coatings and decorative designs (e.g BASWA Textures), the specified sound absorption values may change slightly in individual cases

System structure

System structure BASWA Cool Systems

Fire class B-s1, d0 according to DIN EN 13501-1 is only achieved with Base Cool as the filling layer and base layer!

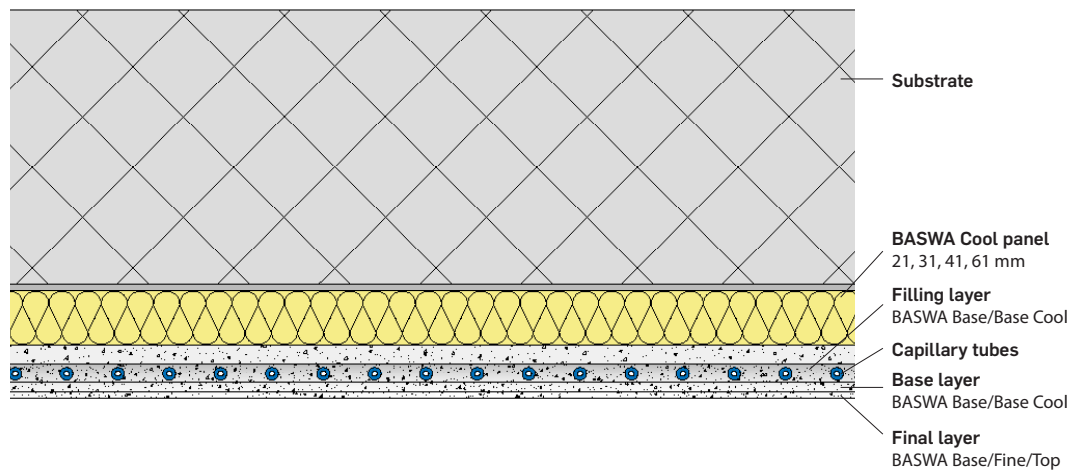

BASWA Cool 30mm:

Concrete

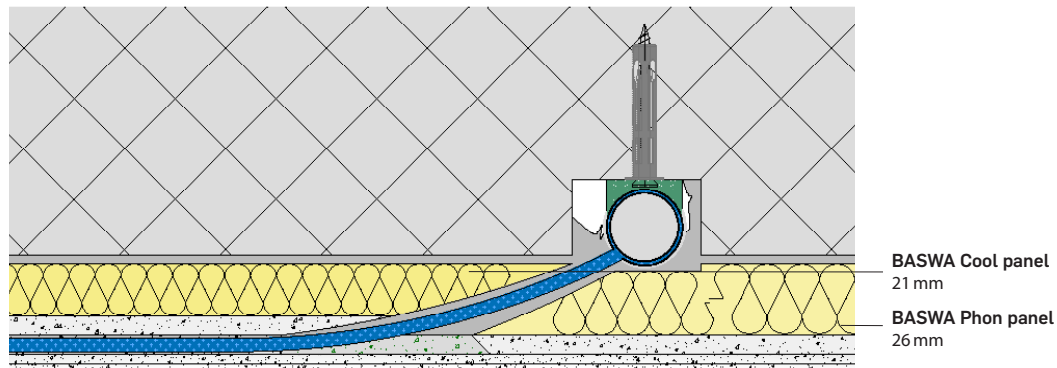

Suspension

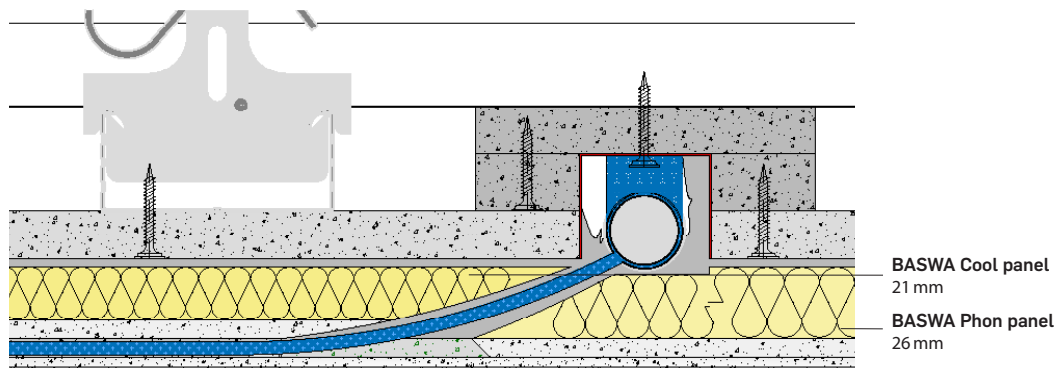

BASWA Cool 40mm:

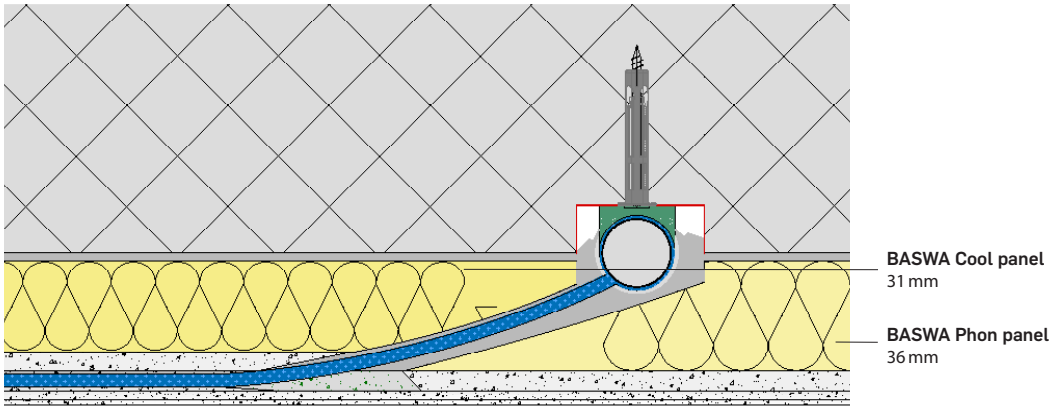

Suspension

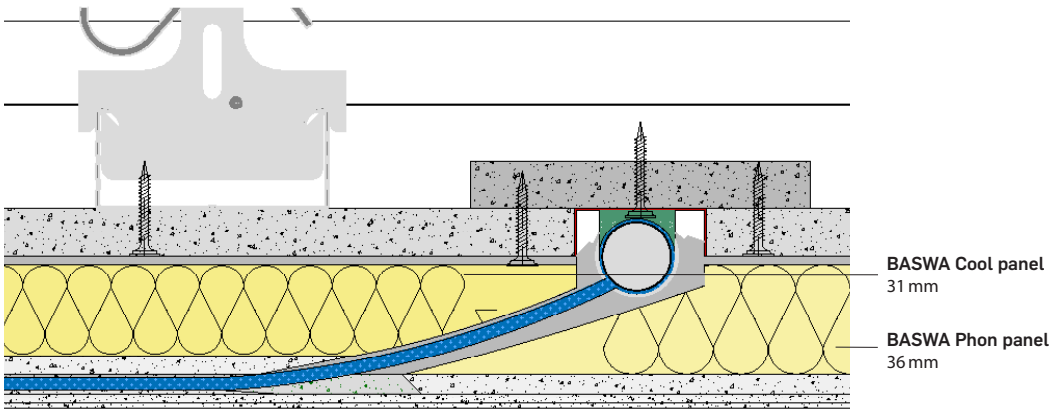

BASWA Cool 50/70 mm:

Concrete

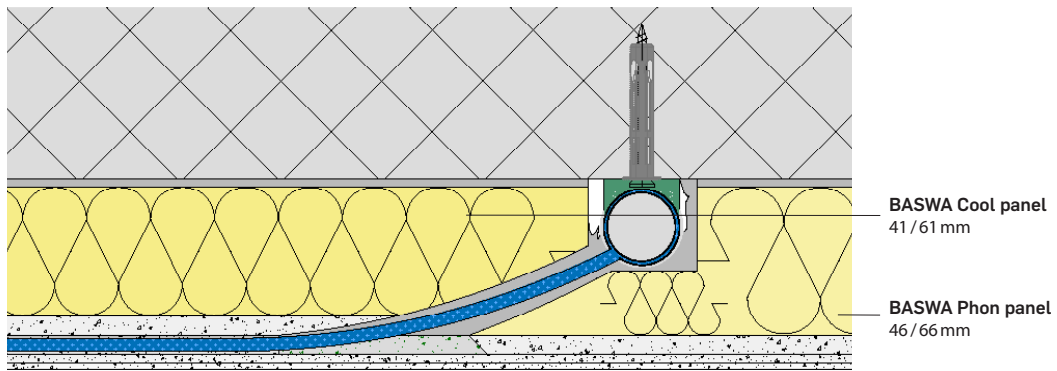

Suspension

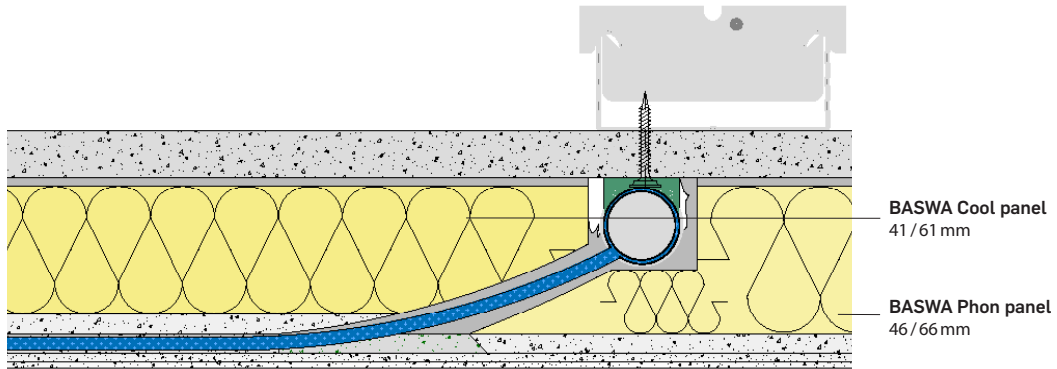

Suspended ceilings

In order to prevent partial contamination of the surface, the system requires a stable, absolutely airtight ceiling substructure. Commercially available suspension systems made of metal rails can be used for the substructure. Wooden constructions are not recommended for this purpose. These may form cracks due to long-term deformation.

A 12.5 mm thick plasterboard or gypsum fiberboard ceiling is suitable as a suspended base for the BASWA Cool system structure. Gypsum plasterboards should preferably be pre-treated with a deep primer due to their tensile strength.

In damp rooms, such as swimming pools, wellness areas and adjacent areas, the substructure must be selected on the basis of structural-physical investigations. All components of the suspension structure must be corrosion resistant. Cement fiber boards or water-repellent dry construction boards, cementitious levelling plasters intended for this application must be used. The BASWA acoustic panels must be bonded with BASWA fix C cement adhesive. See application data sheet for installation of BASWA acoustic systems in damp rooms.

Heating and cooling performance

Specific heating and cooling performance

The use of marble sand in the BASWA acoustic surface coatings means that the BASWA Cool system has outstanding cooling and heating capacity.

In addition to the high thermal radiation output, the systems is capable of fast reaction times due to the thin surface coating of just a few millimeters and the thermal decoupling provided by the BASWA acoustic panels to the substrate.

The rear-side insulation of the BASWA acoustic panels effectively prevents undesired heat loss or heat input to the capillary tube mats.

Equation of the characteristic curve (regarding active area) at nominal cooling water flow according to DIN EN 14240:

A nominal mass flow of 33.8 kg/(h*m²) was specified.

(corresponds to approx. nominal mass flow when used as a cooling ceiling)

$$q = C \cdot \Delta t^n \text{ [W/m}^2\text{]}$$

Constant **C = 6.458**

Exponent **n = 1.072**

Heat output at 15 K average excess temperature: 117.7 W/m²

specific output of the ceiling heating

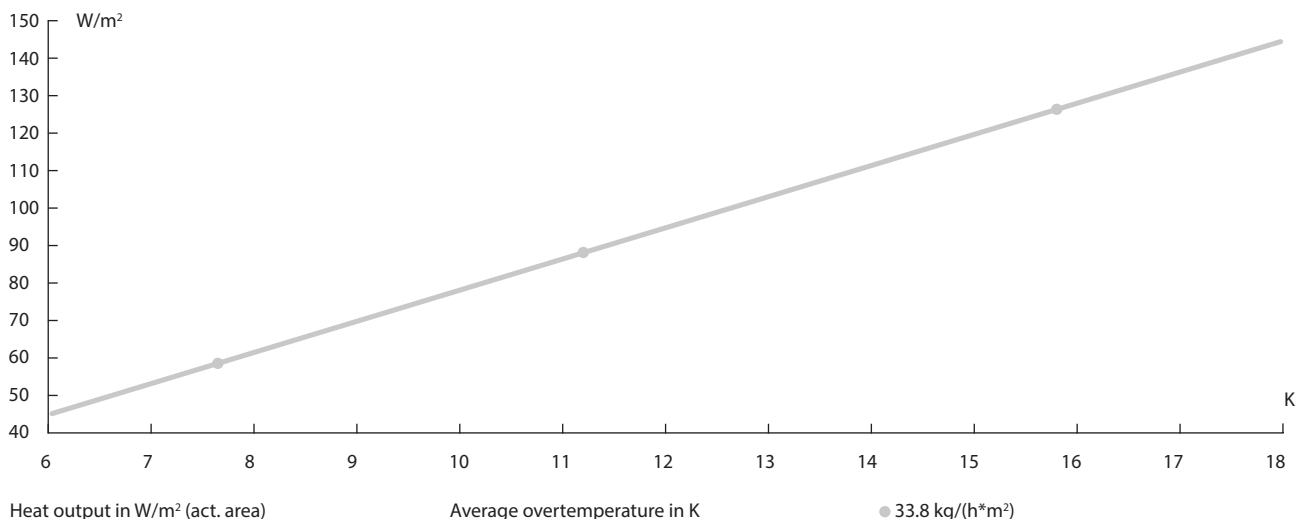

Specific cooling performance

Equation of the nominal characteristic curve with respect to active area:

Coefficient $k = 8.308$

Exponent $n = 1.084$

$$P_a = k \cdot \Delta\Theta^n \text{ [W/m}^2\text{]}$$

Nominal cooling capacity at temperature difference $\Delta\Theta_N = 8 \text{ K}$: 79.1 W/m^2

Calculated nominal cooling water mass flow

with 2 K temperature spread, 8 K temperature difference: **$34.0 \text{ kg/(h}\cdot\text{m}^2)$**

informative: Cooling capacity with temperature difference $\Delta\Theta = 10 \text{ K}$: 100.8 W/m^2

specific performance of the tested cooling ceiling

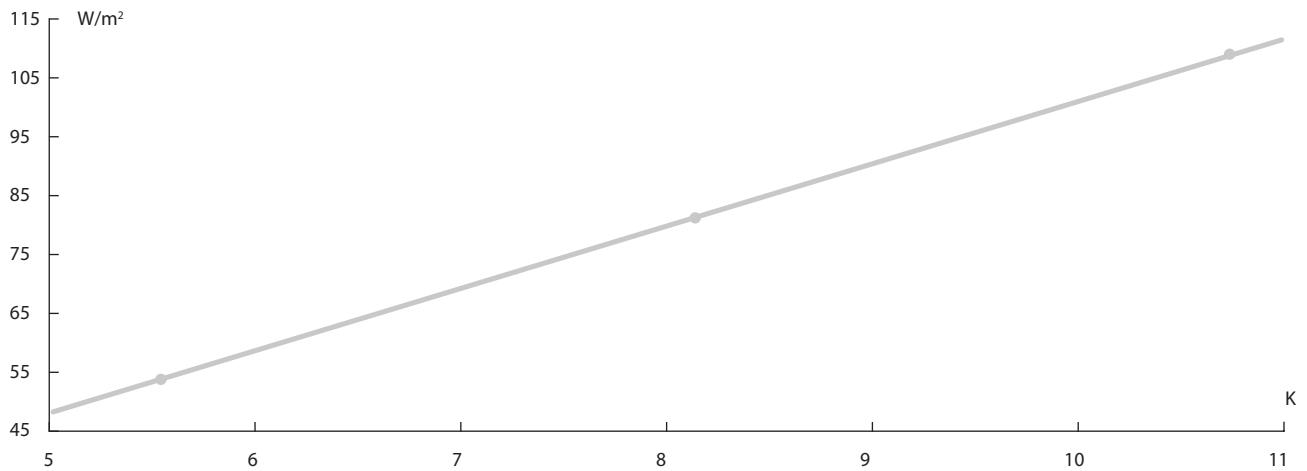

Cooling capacity in W/m^2 (actual area)

Temperature difference $\Delta\Theta$ in K (Undertemperature)

Mass flow: ● $35.0 \text{ kg/(h}\cdot\text{m}^2)$

System and control diagram

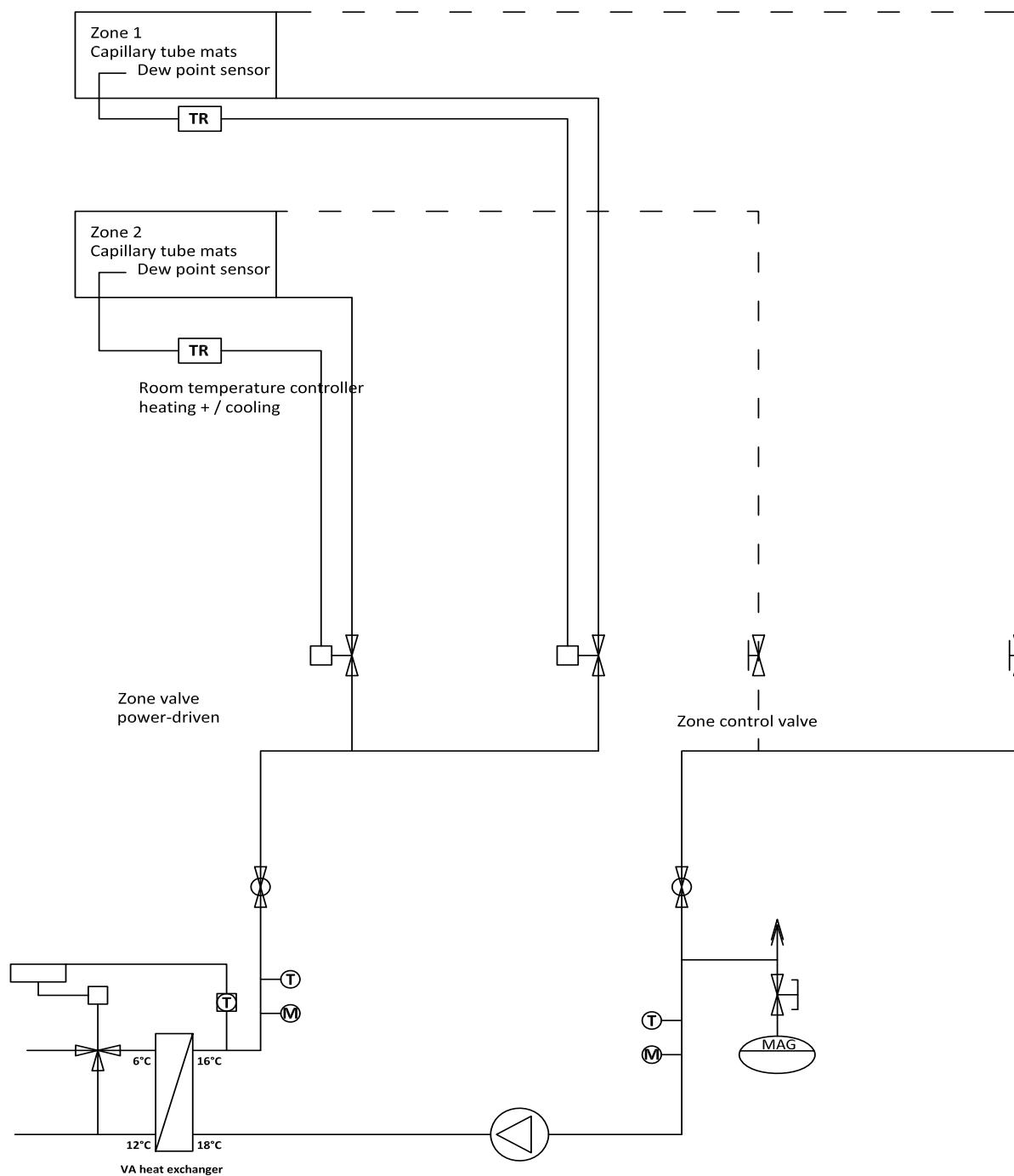

Schematic diagram: Capillary tube system cooling (temperature example)

Planning and configuration bases

Capillary tube mats

- Material Polypropylene (PP), color blue
- Main pipe: 20 x 2.0 mm
- Capillary tube: 3.4 x 0.55 mm
- Capillary spacing: 10 mm
- Length of capillary tube mats: 500-12000 in 10mm steps
- Width of capillary tube mats: 1200 mm from 150 mm in 10 mm steps
- Spec. weight Capillary tube mats: approx. 370 g / m²
- Spec. water content Capillary tube mats: 0.370 l / m²
- Spec. total volume: approx. 740 g / m² Capillary tube surface
- Operating pressure up to 10 bar: PN 10
- Max. recommended operating pressure 4 bar
- Max. permissible heating temperature 60°C
- Pressure loss/circuit: max. 25 kPa

Secondary construction module BASWA Cool

Oxygen diffuses through polypropylene (PP), i.e. it enters through the pipe wall. Until the saturation limit is reached, oxygen, not to be confused with air, penetrates into the system. Since water containing oxygen leads to corrosion, it is essential that the system is made of corrosion-resistant materials. If heat and/or cold generators are not corrosion resistant, a system separation by means of a heat exchanger must be provided to form a secondary circuit.

Material separation by means of heat exchangers between the primary and secondary circuit is state of the art. Within the secondary circuit (capillary tube system) only corrosion-resistant components are to be used.

Material separation by means of heat exchangers between the primary and secondary circuit is state of the art. Within the secondary circuit (capillary tube system) only corrosion-resistant components are to be used.

- Stainless steel plate heat exchanger
- Speed regulated drinking water pump made of stainless steel or bronze
- Diaphragm expansion vessel in drinking water design
- Chilled ceilings distributors made of brass, stainless steel or plastic
- Piping in the secondary circuit at least made of V2A or plastic
- All valves and fittings made of stainless material (V4A, gunmetal, brass, plastic etc.)

Control

The Baswa Cool system can be controlled in terms of system temperature as follows

- Flow temperature control constant with fixed defined setpoint
- Flow temperature control variable according to enthalpy or according to a fixed temperature curve

Room-by-room control by the user is provided by the 2-point actuators (open/closed) on the individual control valves.

Supply pipes to capillary tube mats

For the supply lines to the capillary tube mats, PP tubes 20 x 2 mm are used. For the version with PP tubes, the connection to each other and to the trunk tubes of the capillary tube mats is made with heating element socket welding

Pressure loss capillary tube mats

The capillary tube mats have a low pressure loss despite their small cross sections, due to the parallel flow through the large number of capillaries.

The size of the active areas that can be connected depends on the mass flow, depending on the design. A maximum mass flow of approx. 350 kg/h per hydraulic circuit must be maintained when connecting in PP 20 x 2.0 mm (DN15). This results in pressure losses in the supply lines depending on the length of the connection and flow noise is reliably avoided.

Ceiling Activation Level

Depending on the room geometry and the ceiling design (ceiling installations/ceiling outlets), a correspondingly high degree of ceiling activation can be achieved. The capillary tube mats are manufactured on a project-specific basis and their dimensions are adapted to the requirements. Within a hydraulic circuit, the individual mat modules are to be connected in such a way that an even hydraulic flow is guaranteed. A division into several hydraulic circuits may be necessary, taking into account the maximum pressure losses and the hydraulic flow rate.

Leak test capillary tube mats

Before plastering the ceiling, the system must be subjected to a leak test:

Preliminary test with 3 bar compressed air

After proper installation and before closing, i.e. before completion of the ceiling

The system should be subjected to an initial leak test with 3 bar of compressed air over a period of at least 1 hour.

This measure prevents avoidable damage to components or the structure by the escaping system medium if the circuit is not leakproof due to inattention or defects.

Main test with 10 bar liquid system medium

After successful completion of the preliminary test with 3 bar compressed air, the system is ready for operation with the system medium (as a rule, this is pure, normal water), filled and put under a test pressure of 10 bar.

This test condition must be maintained for a period of at least 24 hours and must be recorded in detail.

After 12 hours at the earliest, the sealing of the ceiling can begin with plastering.

The capillary tube system is to be kept under the aforementioned test pressure in order to be able to immediately detect and immediately eliminate any leaks caused by the plaster application.

If the plastering work is not started immediately after the leak test, the system must first be relieved of pressure, i.e. the pressure in the system must be reduced to the intended operating pressure. The pressure is only to be increased to 10 bar again when the plastering work begins.

Dew point monitoring

In order to prevent the formation of condensation and the resulting staining of the BASWA Cool surface, the temperature and room humidity in rooms with cooling zones must be monitored with a reference control. In this way the flow temperature can always be controlled via the dew point. It is advantageous to dehumidify the supply air so that the regulation functions optimally.

In order to reliably eliminate the risk of falling below the dew point and the associated formation of condensation in all surface cooling systems, each control zone is equipped with one or more dew point sensor. To protect the cooling surface from condensation, the flow through the capillary tube mats is prevented by closing the control valve when there is a risk of dew point. The deactivation of the individual zones can be counteracted by using an enthalpy-controlled VL temperature control.

In large, intensively used buildings, especially office buildings, chilled ceilings are often combined with a supporting ventilation and air-conditioning system so that the temperature rarely falls below the dew point in practice. This is usually necessary in order to supply all users safely with the required fresh air and to dissipate the resulting material loads. The relative humidity is also controlled by the air conditioning system and kept within the comfortable and non-critical range of approx. 50 % relative humidity.

Wall distances BASWA Cool

When planning the capillary tube mats, a distance of at least 15 cm to walls must be observed. The installer must adhere the BASWA panels and fill the joints correspondingly. It should also not be forgotten that there must still be sufficient space for the connections of the capillary tube mats.

Installation time

The specified installation time is based on a working group of 3 to 4 people and a ceiling size of 40–60 m². The drying times of BASWA joint and coating compounds depend on the room climate conditions. Ideal conditions being 20 °C room temperature/50% relative humidity.

Allow each step to dry completely.

BASWA Cool Classic Base / Fine / Top

Days	1	2	3	4	5	6	7	8	9	10	11	12	13	14	15	16	17
BASWA Cool panels bonding	●																
BASWA Cool panels grouting	●																
Grinding joints and BASWA Cool Panel flat			●														
Fasten, clamp and fix capillary tube mats			●														
Pressure test			●														
Remaining surface in the edge area and climbing zones. Adding BASWA Phon acoustic panels					●												
Additional BASWA Phon acoustic panel grouting					●												
Grinding joints flat Flatness control of the completed area		Drying		Drying		Drying		●		Drying		Drying		Drying		Drying	
Filling layer: Interspace of the capillary tube mats with Filling BASWA Base/BASWA Base Cool								●									
Covering layer: BASWA Base/BASWA Base Cool priming coat apply to the whole surface												●					
Check the surface layer for flatness, if necessary, grind again carefully															●		
Final coating: Apply BASWA Base/Fine/Top over the entire surface															●		
Follow-up work																	●

Preparation and planning

Requirements and prerequisites

General information

Correct planning, careful site preparation and execution of the work under optimum installation conditions are necessary to guarantee the surface quality and service life of a BASWA Cool acoustic system.

In order to ensure the acoustic and aesthetic quality as well as the longevity of the BASWA Cool surfaces, the BASWA Cool systems are exclusively installed by trained and certified companies. The experience of the executing team, a suitable scaffolding and adherence to the installation guidelines are essential prerequisites for the installation of the BASWA Cool System.

Standards and recommendations

The current guidelines of the company BASWA acoustic AG must be observed for both types of work. The agreed terms and conditions as outlined in the planning documents, installation guidelines, and the general terms and conditions of BASWA acoustic AG take effect on the date of the contract.

Certification of installing companies

In order to qualify for the installation of BASWA acoustic systems, it is necessary to attend a certification course. BASWA acoustic AG products can only be purchased from certified companies.

Companies that are about to carry out a project with BASWA Cool acoustic systems should attend a installation course at the respective BASWA company location 4–6 weeks before the start of the project. Information about the courses on offer can be obtained from the regional contact person at BASWA acoustic AG. Upon completion of the training, the course participants and the company receive a certificate which identifies them as a certified BASWA installer. On request, BASWA provides architects and planners with a list of certified and experienced companies.

Companies that do not carry out any projects for two years lose certification. However, the company is free to attend another certification course.

Building and room conditions

Installation

- Temperatures of at least 15°C to max. 30°C must be maintained during installation until complete drying.
- Avoid draughts during installation.
- During the drying time no temperature gradient of more than 10 °C may occur!
- The drying time is considerably longer with high humidity in the building.

Building use

- The products of the BASWA systems are designed for conventional room uses.
- Recommended temperature: min 17.5°C to max. 27.5°C.
- Relative humidity: DIN EN 13964 - Class A, 25°C/fluctuating relative humidity up to max. 70% (project specific after consultation also up to 80%).
- At temperatures above 0°C, humidity above 80% RH promotes the risk of microbial growth.

Dew point

- If there are strong fluctuations in temperature and relative humidity, care must be taken to ensure that the dew point is not located on the surface or within the BASWA acoustic system.
- The design of the building insulation and the commissioning of air conditioning systems must be planned and controlled accordingly.
- The moisture caused by condensation in the room air can cause damage to the BASWA Cool acoustic system.

The use of gas heaters is not recommended. These usually increase the relative air humidity, whereby the drying time is considerably extended!

Drying times, time planning and finish dates

The minimum drying times between the individual installation steps must be observed. These minimum drying times refer to ideal indoor climatic conditions: 20°C room temperature and 50 % relative humidity. Cold and humidity extend the drying times considerably. Fans, with or without heating, favour drying times to ensure compliance with the construction program. Before each working step, a complete drying of the previous coating masses must be ensured.

Jointlessness

BASWA Cool acoustic systems do not require joints as a system, but the specific properties of the ceiling or wall surface, as well as the shape of the construction, material expansion, possible subsidence or deformation of the shell must be taken into account. Joints in the subfloor caused by the construction must be taken over in the BASWA Cool system structure.

The guidelines of the product suppliers of the selected underneath material must be observed according to their set regulations.

Side light conditions

Surfaces that are exposed to strong side light should always be executed with a two-layer system (Classic Base/Fine/Top). For this lighting situation, the surface quality level Q3 must always be met.

It is not advisable to plan lateral illumination of the BASWA Cool surfaces with LED luminaires. Under the influence of the lateral LED light, the slightest traces of installation and irregularities become highly visible. It is therefore advisable to have a surface sampled in advance under original lighting.

Quality levels

Unless otherwise agreed, the standard surface quality is always Q2. If increased requirements are placed on the evenness of surfaces, this must be expressly stated in the bill of quantities and contractually agreed.

The surface quality Q4 cannot be achieved with the smoothed BASWA Cool acoustic systems for reasons of application and material technology.

Flatness and dimensional tolerances

In the case of increased requirements for surface quality Q3, additional flatness tolerances must be contractually agreed. These already apply to the preparatory work on the substrate to which the BASWA acoustic systems are applied.

Information can be obtained from your regional representative.

Scaffolds

In order to achieve the best possible surface quality, the coating installation are to be carried out with the aid of surface frameworks. This ensures an unhindered, continuous workflow, especially during the smoothing of the final layer.

The height difference between ceiling and surface scaffold must be adjusted to the body size of the installation team (optimum difference between scaffold and ceiling between 185 and 195 cm).

Watch your step! Wearing headgear during coating work can damage the freshly created surface!

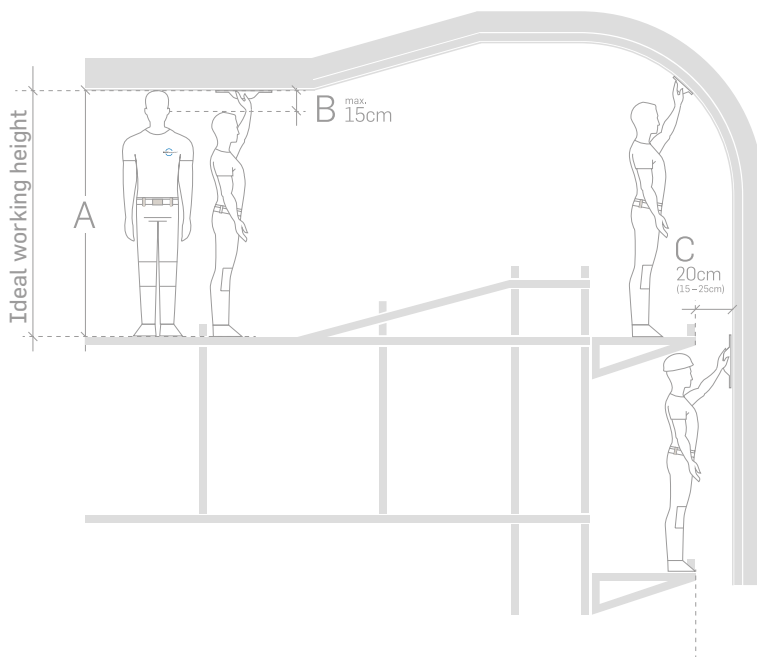

Wall scaffolds

When applying coating compounds to vertical surfaces, it is advisable to work on facade scaffolding constructions using scaffolding brackets. A settling in the middle of the surface leads to visible traces of installation. The distance between the surface and the scaffold bracket should be at least 15 cm, optimally 20–25 cm. The national safety regulations regarding maximum distances must be observed.

Temporary safety anchors in the wall construction should be avoided wherever possible.

Subsequent work

Subsequent installation work by other trades on BASWA system surfaces (e.g. installation of luminaires) must be carried out carefully and with clean gloves. All planners and craftsmen involved in the construction must be made aware of the consequential costs arising from subsequent damage or planning changes.

Repairs

As is the case with all surface coatings in building construction, BASWA Cool surfaces are only partially repairable (depending on the size and illumination of the repair points). The repaired area usually has a slightly different structure and becomes visible under unfavorable incidence of light. In the case of larger damage, it is advisable to re-coat the surface segment completely. Furthermore, it is advantageous to divide the surfaces into smaller areas by means of separating joints.

Damaged capillary tubes

If the capillary tubes are damaged, the following measures must be taken:

- Close the shut-off valve of the cold exchanger.
- Contact suitable qualified personnel immediately!

Further steps:

The defective capillary tubes are sealed by heating and a special pressing technique. A lower system performance is not to be expected by this measure.

Substrate for BASWA Cool Acoustic Systems

General information

In addition, the following requirements still have to be checked:

- Must be mineral, solid (concrete)
- Must correspond to the required final shape, flat surface according to the requirements for the flatness of component surfaces according to DIN 18202
- Must be stable
- Free of sintered layers and switch release agents
- Dust-free, free of impurities and harmful efflorescence
- Load bearing, strong and sufficiently dimensionally stable, adhesive tensile strength $> 0.3 \text{ kN/m}^2$ (30 kg/m^2)
- Airtight
- Crack-free
- Guarantee of dew point prevention
- Dry (residual moisture $\leq 3 \text{ mass } \%$), not water-repellent

In order to guarantee the service life and surface quality of a BASWA Cool acoustic system and to prevent long-term damage, the substrate to which the system is bonded must first be checked for five points.

1. Adapt the substrate to the required final shape

Flat, parallel or exactly curved: With the adhesive and coating masses as well as the grinding of the acoustic panels, unevenness of max. 4 mm can be levelled out. Increased requirements for flatness (Q3), dimensional tolerances and dimensional accuracy must be met with the substrate.

Prior to use, treat strong formwork offsets and burrs on concrete surfaces ($>3 \text{ mm}$) (peel off, partially level or apply full surface levelling layer). Please note: The levelling layer must dry completely before the acoustic panels are bonded (lead time of at least one to two weeks/or one day drying time per millimeter of levelling plaster).

2. The substrate must be stable

No cracking or movement: Taking into account the specific properties of the ceiling or wall surface such as the shape of the structure, material expansion, possible subsidence and/or deformation of the shell, surfaces can be designed up to the maximum size of the respective substructure.

The guidelines of the product suppliers of the selected substructure must be strictly observed. In order to prevent the formation of cracks, expansion joints caused by design must be incorporated into the BASWA acoustic systems. No warranty for non-mineral substrates such as OSB, MDF, metal plates, etc.

Formation of expansion or separation joints: For large areas, depending on the specific properties of the building structure or the construction process, the formation of separation joints is necessary. The following principle shows how air circulation to the cavity can be avoided, thus excluding partial contamination.

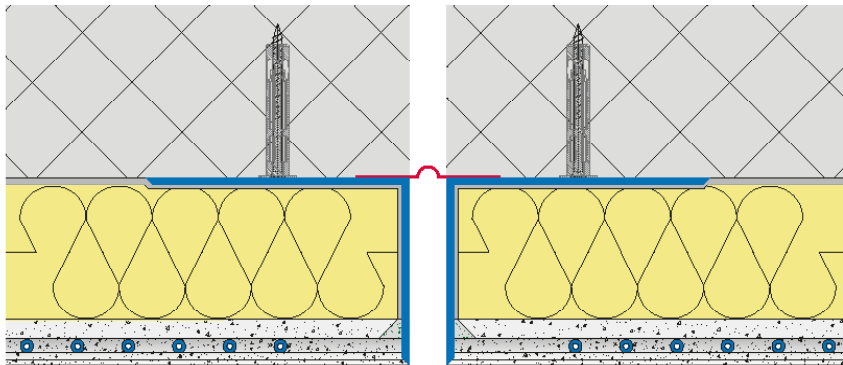

D_053

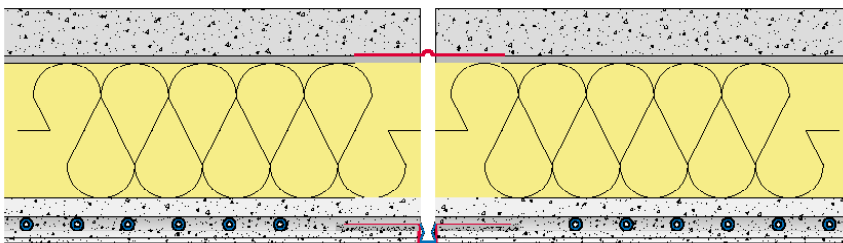

D_099

3. Adhesive tensile strength $>30 \text{ kg/m}^2$

The substrate to be coated must have an adhesive tensile strength of at least 300 N/m^2 . If this is not guaranteed, measures must be taken to achieve this adhesive tensile strength. For suspended ceilings, the spacing of the suspended structure must be selected so that the entire ceiling structure can support the additional load of the BASWA acoustic system. Gypsum plasterboards should preferably be pre-treated with a deep primer due to their tensile strength.

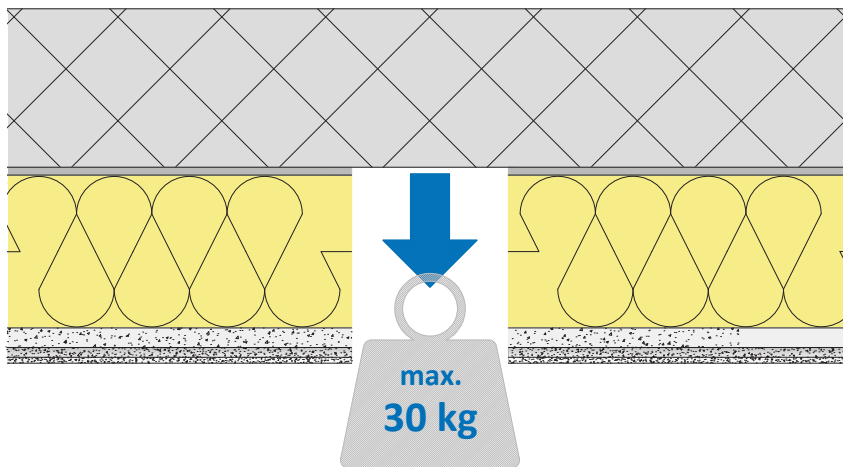

Additional mechanical fastening

For existing ceilings (plaster, paint), the adhesive tensile strength and moisture sensitivity must be checked beforehand. If the adhesive tensile strength is less than 300 N/m^2 , the defective substrate must be removed accordingly or strengthened by means of a depth substrate matched to the existing coating.

Additional mechanical fastening of the bonded acoustic panels with the BASWA fastening rod can only have a supporting effect to prevent third-party damage.



BASWA additional
mechanical fastening

4. The substrate must be airtight

In the case of suspended ceilings, all panel joints must be filled and reinforced in such a way that a level, stable and closed substrate is created (airtightness!). All installation penetrations and gaps to connections to components must be sealed airtight with vapor barrier tape before the acoustic panels are bonded. These seals prevent air circulation through the open-pore acoustic system (prevention of partial dust deposits in the final coating). In order to ensure airtightness over the entire service life of the installation, an adhesive tape should be selected which ensures a corresponding long-term adhesion (e.g. vapor barrier adhesive tape).

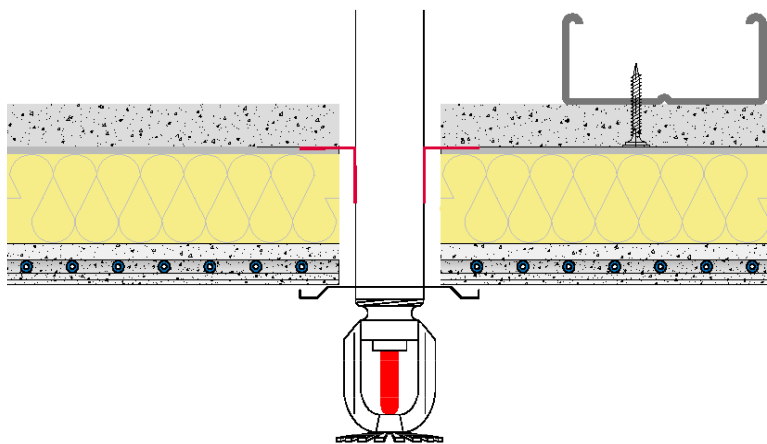

D_074

Not permeable to air through
vapour barrier adhesive tape (red)

Ageing process with air flows

In the event of leaking connections to suspended surfaces, the air circulates through the open-pored acoustic system. The dust carried along is filtered in the final coating and leads to strong partial discolorations over the course of the service life.

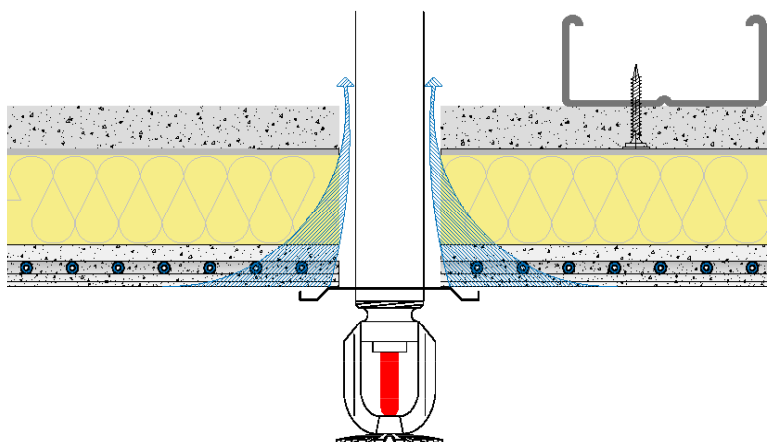

D_074

Air permeable without
vapour barrier tape

5. Calculation and prevention of the dew point

When planning a BASWA Cool system adjacent to the outer shell of the building, the dew point must be calculated and checked in advance by a specialist planner (e.g. at the top floor/outside walls/balcony, terrace undersides/cold rooms, etc.).

If the dew point is within the BASWA Cool system, the surface will change color irregularly within a very short time due to condensation (increased dust adhesion to the moist coating surface).

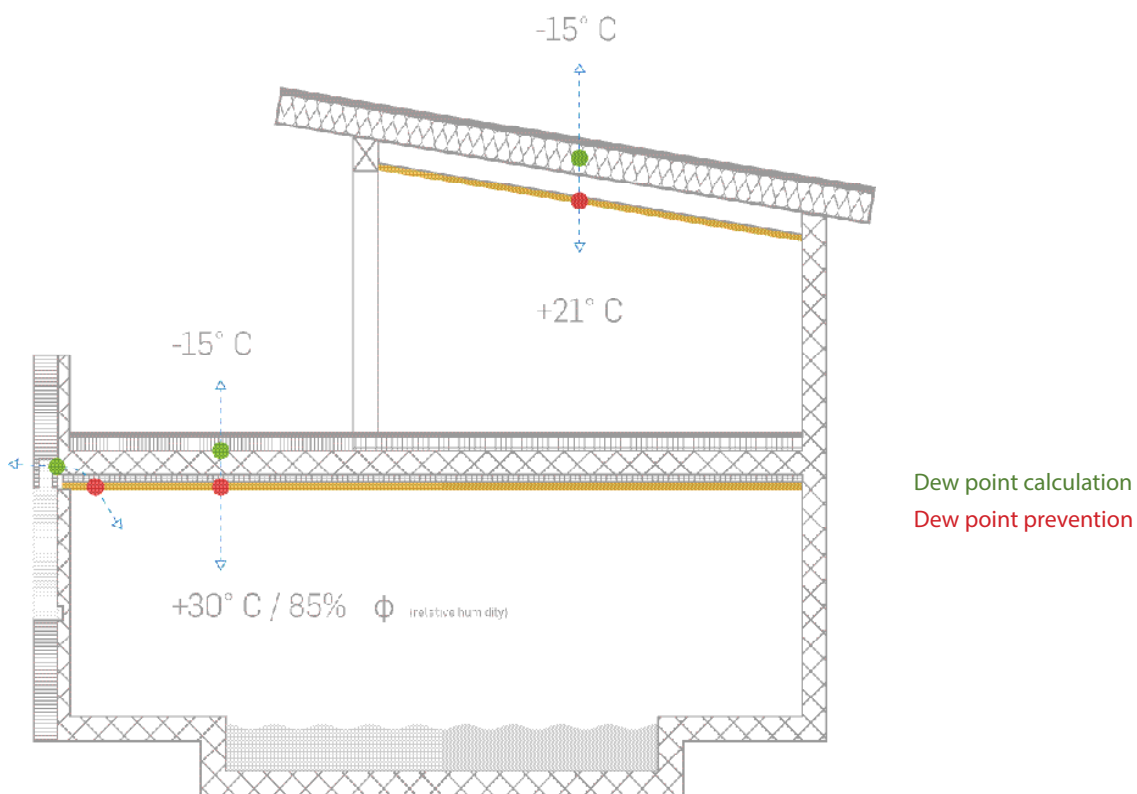

BASWA Cool Classic Base/Fine/Top	1/U	U-value (W/m ² K)	λ Lambda-value (W/m K)	R (m ² K/W)
30 mm	0.68	1.47	0.044	0.68
40 mm	0.96	1.04	0.041	0.96
50 mm	1.25	0.80	0.040	1.25
70 mm	1.82	0.55	0.038	1.82

BASWA Colours

The choice of colours for the BASWA coating compounds is almost unlimited. The coating compounds can be coloured in almost any desired shade. After delivery of a colour reference, a colour sample is created by BASWA. This must be confirmed by the architect or client.

In order to achieve coloured surfaces, the BASWA coating materials are dyed at the factory to order. The colour formulations are determined individually for each new colour in the BASWA acoustic AG laboratory; due to the special properties of the porous surfaces, each colour formulation is compared by eye with the original pattern.

The pigment preparations are mixed into the coating masses without further addition of additives. The coloured products are then applied on site. Furthermore, all desired colours can be mixed on order according to references of common colour cards or physical samples.

The products are made from natural marble sand. Untreated natural products are always subject to minimal colour variations and can easily influence the basic tone of the colour. The standard white of the BASWA coating dimensions corresponds approximately to NCS S 0500-N.

Due to the porosity of the surface, finished BASWA surfaces can have very different effects depending on the incidence of light. Similar to other mineral systems, a slight cloud formation cannot be excluded with coloured surfaces.



Light reflection of BASWA coatings

Light reflection on surfaces in rooms should be as high as possible, because poor lighting conditions can lead to fatigue, headaches, poor eyesight and noticeably reduced productivity at the workplace.

The BASWA acoustic coatings with white surface have an optimal light reflection between 75 -79%. This enables a high level of light diffusion and thus an even distribution of light, which can considerably increase well-being. Artificial and natural light is also used efficiently and can also contribute to energy savings.

The following values refer to measurements carried out according to DIN EN ISO 11664-4 according to CIELAB system.

Coating	light reflection	Degree of whiteness (CIE-Y-Value)
BASWA Base	0.75	89.61
BASWA Fine	0.77	90.28
BASWA Top	0.79	91.30
BASWA Fresh	0.76	89.66
BASWA Casual	0.76	89.85

Surface structures and effects

BASWA Textures

The smooth finish of the BASWA Cool systems with their fine, smooth surface texture supports the design of modern, timeless architecture. Using special installation techniques, various plaster structures can be imitated, which are often used in the acoustic renovation of historic buildings.

- Spray application
- Brush Texturing
- Modeling the trowel

Sparkling effects with BASWA Shine

The BASWA Shine surface refinement gives the surface a glittering effect without significantly impairing its acoustic performance. The mica dispersion BASWA Shine is used for the subsequent finishing of BASWA acoustic surfaces. It must be directly illuminated with the help of the lighting concept in order to achieve the glitter effect.

On request, BASWA acoustic AG develops special surface effects in cooperation with customers.



**Protection, cleaning,
maintenance and refurbishment**

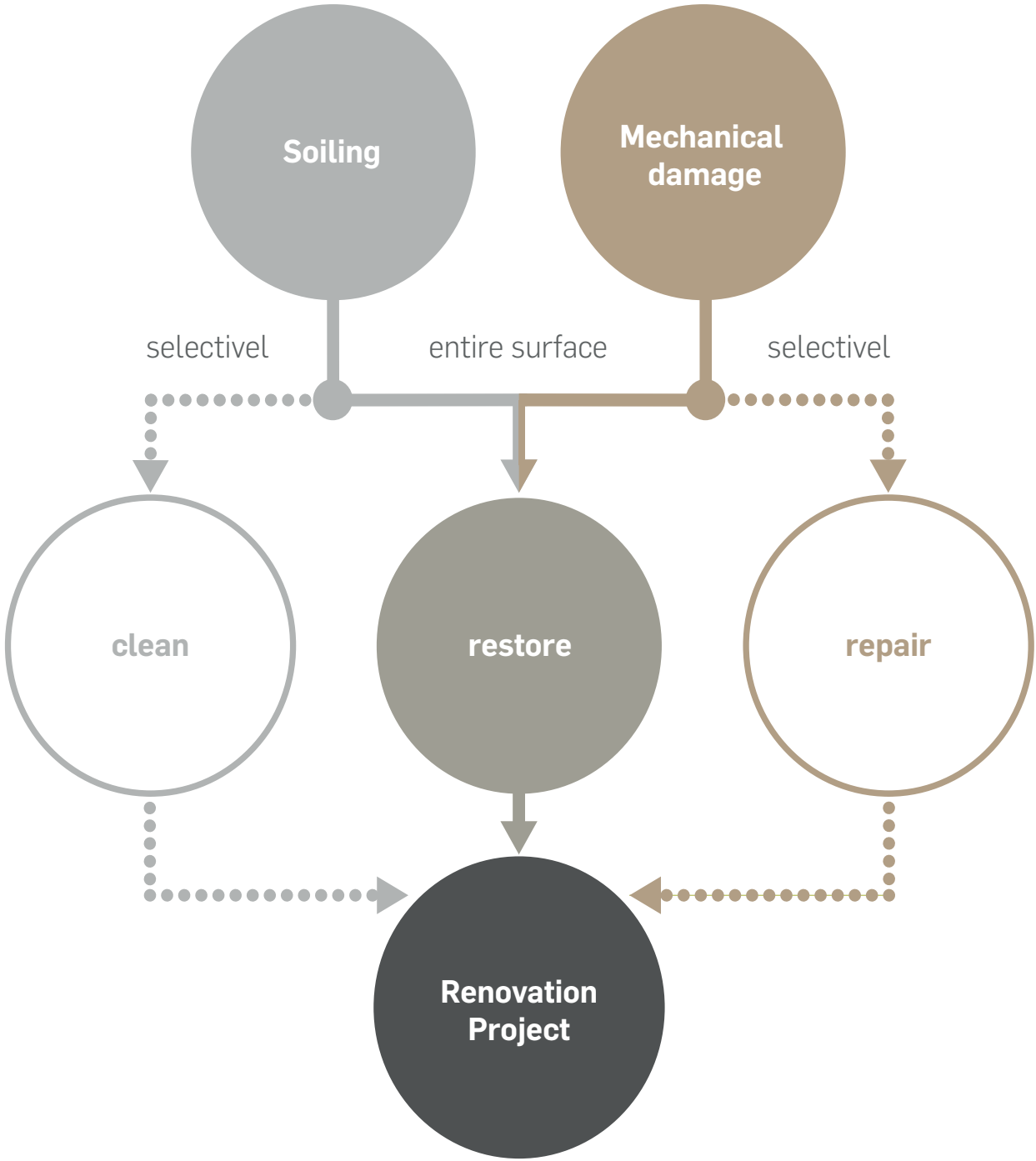

General information

BASWA Cool systems are fine-pored surfaces that absorb sound energy. The pore size and the number of pores significantly determine the absorption properties of the various acoustic systems. In order to maintain the porosity of the surface and thus the effectiveness of sound absorption, BASWA Cool surfaces must not be painted under any circumstances.

Aging of BASWA Cool systems

The open-pored BASWA Cool surfaces act like a filter due to their permeability to changes in air pressure. Over the years, fine dust can therefore settle in the pores, which can lead to a discreet greying of the surfaces. Under normal conditions this greying is very minimal and hardly visible. Ageing has no influence on the acoustic performance of the system.

Since the BASWA Cool systems are installed exclusively on airtight, closed surfaces, an air flow through the system is excluded. As a result, aging and greying therefore take place evenly and slowly.

Furthermore, the following must be observed:

- Do not attempt to clean with water or non-BASWA cleaning agents!
- In general, only touch the surface with clean hands or wear clean gloves.
- Always protect BASWA surfaces with masking tape during connection work.
- Do not rub superficial, partial soiling (dust, fingerprints etc.), otherwise the dirt will penetrate deeper into the por.
- Do not paint BASWA acoustic ceilings!

Surface protection

BASWA Protect is a specially developed premium impregnation system to achieve deep water repellency with optimum protection for BASWA acoustic surfaces. The acoustic performance of the treated surface is not impaired. The deep penetration of BASWA Protect into the acoustic system results in significantly lower dirt and water absorption. This prevents the immediate ingress of liquids and thus reduces the absorption capacity of liquid type dirt and dirt particles that have combined with liquids. Furthermore, the impregnation can have a positive influence on the cleaning of BASWA surfaces and the longevity of BASWA surfaces.

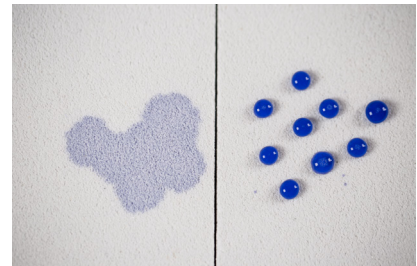

BASWA Protect (right)

Cleaning

An der Dry dirt or dust adhering to the surface can be removed with an adhesive tape or a fine brush (attached to a suction device).

Partial organic soiling (drink stains, grease, nicotine etc.) can be removed with BASWA Blonde (bleaching agent) or BASWA Clean (special enzyme cleaner). Prior treatment of the surfaces with BASWA Protect facilitates cleaning and maintenance work.



BASWA Clean

BASWA Fresh

The mineral dispersion technology of BASWA Fresh is used to renovate age- and use-related discolorations of BASWA surfaces. BASWA Fresh is a part of the BASWA maintenance and refurbishment product line and can therefore be combined with other applications, such as surface cleaning with BASWA Clean. Treating surfaces with BASWA Fresh, however, does not replace full renovation, but can considerably extend the service life of a BASWA surface. The professional application refreshes age-related discolorations as well as faded BASWA surfaces and gives them back their new appearance. The acoustic performance is virtually unaffected. BASWA Fresh is not suitable for re-coloring existing BASWA acoustic surfaces.



BASWA Fresh

Note! With colored BASWA acoustic surfaces treated with BASWA Fresh, color differences in relation to the original color cannot be ruled out. BASWA Fresh may only be used by specially trained companies (certified BASWA partners).

BASWA Fresh is supplied in as close to the original color of the existing surface as possible.

BASWA Casual

BASWA Casual is the acoustic spray plaster, which is used for the renovation of existing BASWA acoustic surfaces.

In the event of renovation, BASWA Casual is applied to the existing acoustic system in one to two stages. The result is a slightly textured, homogeneous, jointless surface. Soiled or damaged areas or surfaces must be cleaned in advance with suitable agents (e.g. BASWA Clean) and partially repaired.

As part of a complete renewal, the BASWA coating compounds can be removed with the aid of grinding equipment and then the coating compounds can be reapplied.

Depending on the BASWA System, it is also possible to apply a new final coating. In this case, however, a slight impairment of the absorption capacity must be accepted.

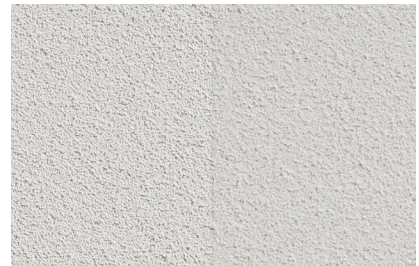

BASWA Fresh (left)



BASWA Casual

BASWA maintenance and renovation concept

BASWA Cool ceilings should only be refurbished by specially trained companies. The specialized company investigates the case and decides which measures and methods are most suitable for refurbishment. Depending on the soiling, the size of the ceiling and the available time window, various measures have to be combined for a successful renovation.

Each renovation is unique and individual in needs, this is highly considered when finding a solution for your project.

Common construction details



Common construction details

For the planning of various construction details such as surface connections, edge formation, separating and expansion joints as well as various installations, a large number of schematic detail drawings are available to you on our website.

The following pages describe the most important points of the most common detailed solutions by topic.

Surface connections to vertical components

Wall connection with separating strips

In order to prevent uncontrolled cracking, the coating compounds of all BASWA acoustic systems must be separated from adjacent surfaces and/or structures (e.g. columns, wall connections, window or door frames made of metal or wood and others) with a ceiling separating strip.

Depending on the optical or building physics requirements, this can be done with a ceiling separating paper or 3 mm thick PE foam separating strips.

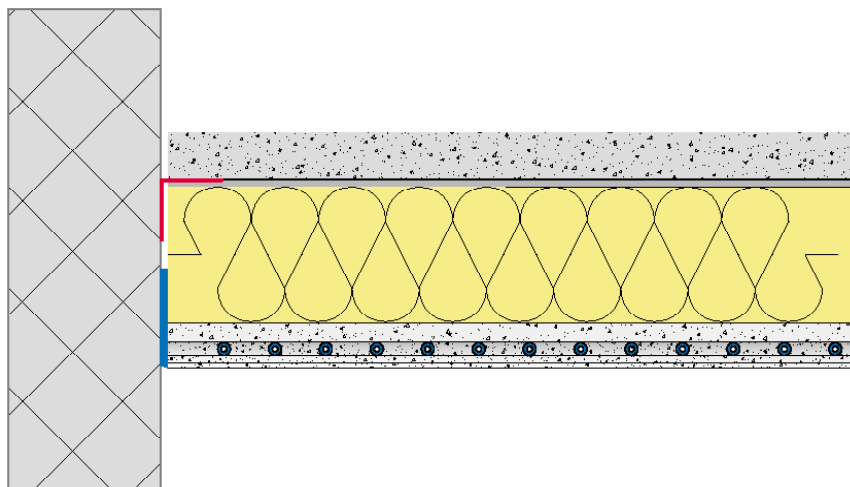

D_014

Wall connection with separating cut

For connections to drywall or wooden walls, we recommend the use of a 2 to 3 mm wide partition cut. This is due to the higher mechanical vibrations and expansion coefficients in function of humidity and temperature.

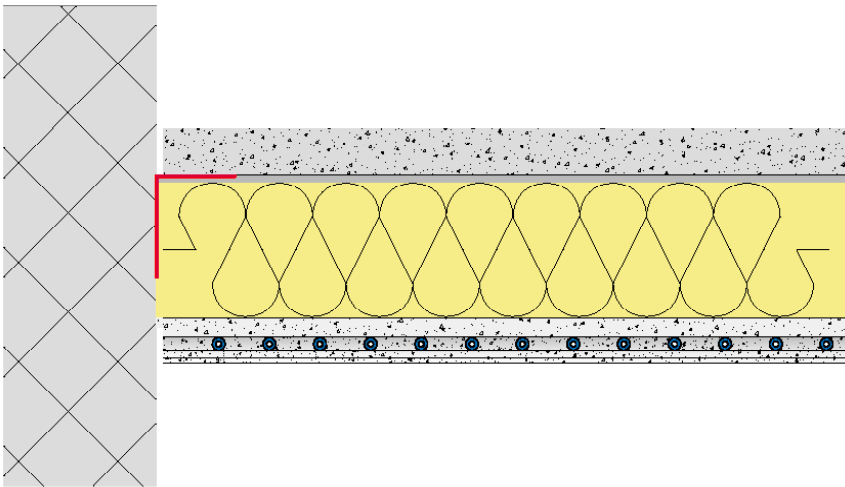

D_006

Wall connection with shadow gap

Individual shadow gaps can also be formed according to the adjacent drawing. This application minimizes, for example, the color transformation of walls in museums or provides protection against mechanical damage.

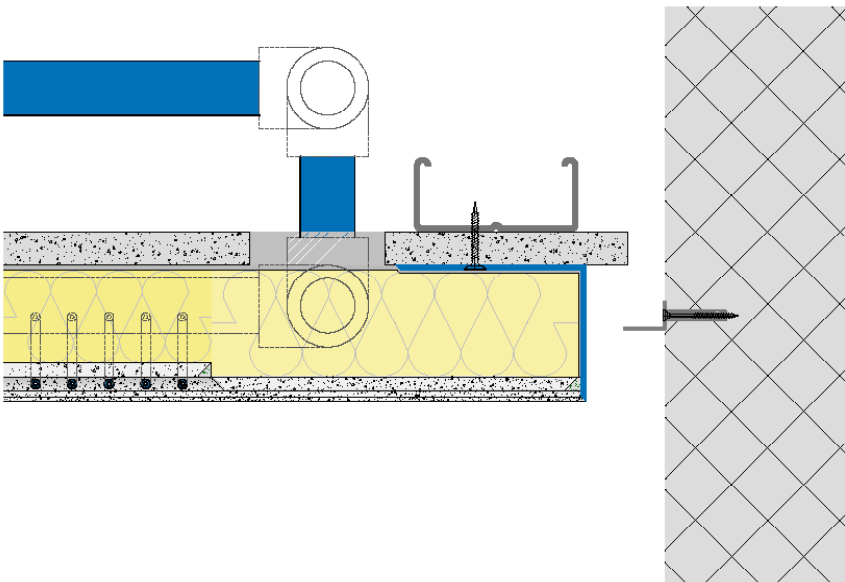

D_018

Edge finishes

Edge protection profiles

BASWA L-angle profiles made of PVC or powder-coated aluminium can be used to build edges. (recommendation BASWA Art. Nr. a271 and a348)

The L-angle profiles must be installed to the required system thickness (30, 40, 50, 70 mm). This provides protection against mechanical damage. On surfaces exposed to heat radiation, there is a risk of cracks forming between the profile and the acoustic plaster. (Observe expansion coefficient aluminium, PVC!)

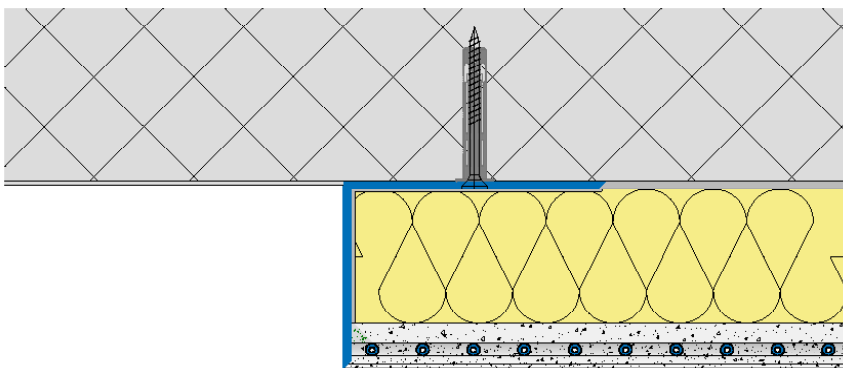
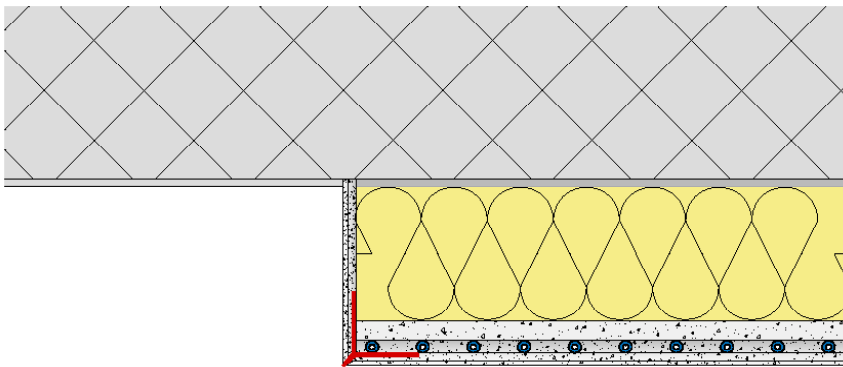

Spotlights, luminaires, tracks, pendants, etc.

Openings for installations such as recessed luminaires, surveillance cameras, motion and fire detectors, loudspeaker boxes, etc., can be carefully made after the final coating with a drill bit. All board faces of the penetrations (vertical mineral wool faces) must be sealed airtight by smoothing off an approx. 2 mm thick gypsum filler application and/or by masking with aluminum adhesive tape. This prevents partial contamination by air flow.

Installation of light covers

Depending on the type of luminaire selected, the luminaire can be mounted directly on the substructure or in the suspended ceiling using light covers. The variant shown shows light bands without visible lamp bezel.

Important: Depending on the heat development and expansion of the respective material of the luminaire, cracks may form in the adjacent coating.

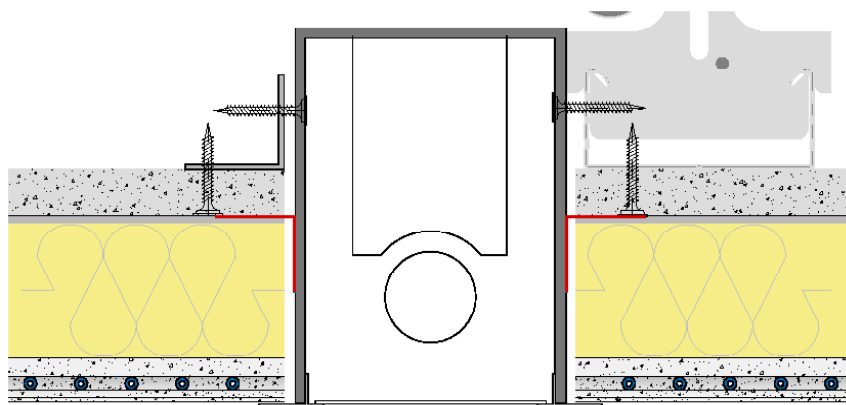

D_061

Mounting rings

In order to prevent damage to the edge during installation or maintenance work on installation elements, the cover rings should be at least 1 cm wide. In the case of installation elements with narrow cover rings, a metal sleeve (prefabricated metal ring) in the diameter of the required ceiling cutout can instead be fitted in advance in the penetration area of the substructure.

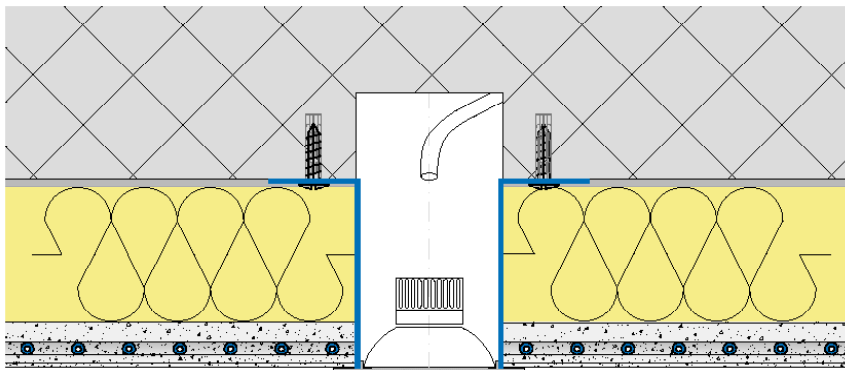

D_072

BASWA installation platform (BASWA IP)

The BASWA IP is used for the partial installation of built-in elements with expansion springs, which require low construction thicknesses for fastening. The pressure-resistant nature of the IP prevents the edge of the ceiling cut-out from breaking out and reduces the need for wide cover rings.

The BASWA IP is based on a pressure-resistant, open-pored panel. The installation platform is calibrated to the respective thickness of the BASWA Phon acoustic panel and is available with or without opening cut-out.

BASWA IP Standars

200 mm x 200 mm for $d < 140$ mm

300 mm x 300 mm for $90 \text{ mm} < d < 220$ mm

Other dimensions are available on request.

They are glued to the respective substrate, screwed mechanically as required and sealed airtight all around. The acoustic panels are then fully connected to the installation platform, the joints and screw holes are filled with BASWA Fill and ground at the same level.

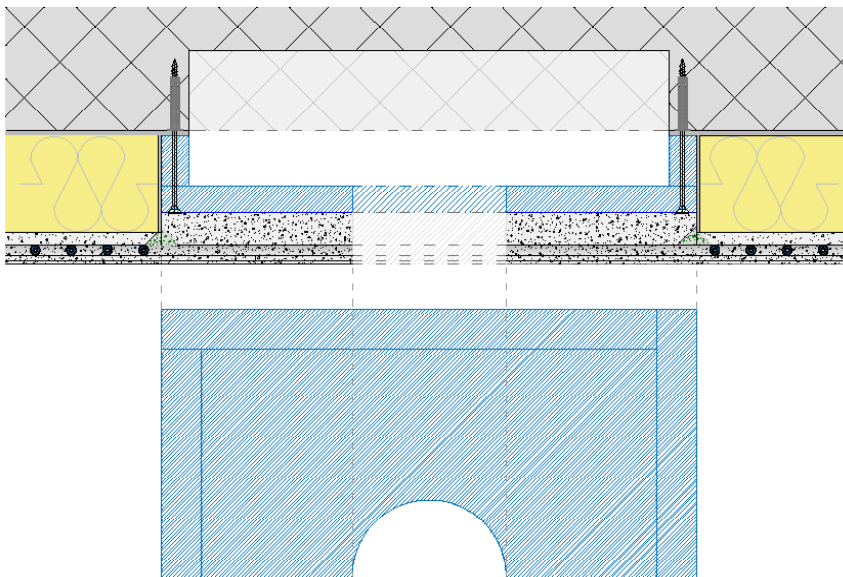

D_070

Service openings

The BASWA inspection opening flaps are individually height-adjustable and already RAL9010 PUR-coated. A special breathable acoustic inlay in the door frame prevents the surfaces from ageing differently. It is important that the side connection between the outer frame and the substrate is sealed airtight beforehand. This prevents air from flowing through the adjacent acoustic system.

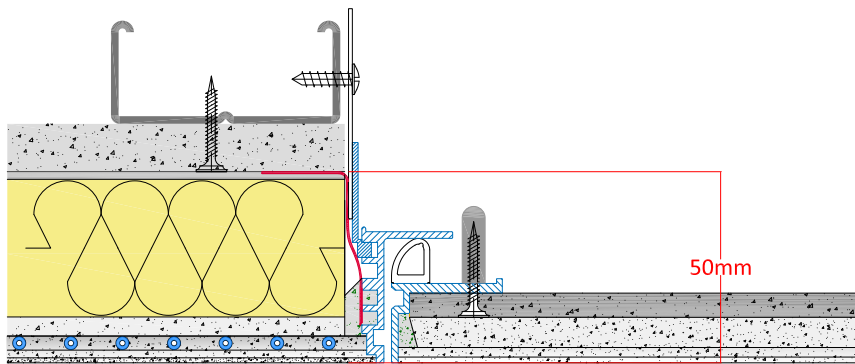

D_067

Legal notice

The above information, in particular the suggestions for installation and use of our products, are based on our knowledge and experience in normal cases, provided that the products have been stored and used properly. Because of the different materials, substrates and different working conditions, a warranty of a work result or a liability, regardless of the legal relationship, cannot be based on these references or on verbal advice, unless we are guilty of intent or gross negligence in this respect. In doing so, the User must prove in writing that he has provided BASWA in a timely and complete manner with all the knowledge required for BASWA's proper and promising assessment. The user must test the products for their suitability for the intended application. Product specifications are subject to change without notice. The industrial property rights of third parties must be observed. In all other respects, our respective terms and conditions of sale and delivery shall apply. The most current product data sheet applies, which can be requested from us.

Planning documents BASWA Cool.

The **latest valid version** of this document can be found on our website www.baswa.com.

BASWA acoustic AG +41 (0)41 914 02 22 www.baswa.com

